



## Carbon-Ply Composite Repair System (CRS)

The following Installation Guidelines are intended to assist a trained, pre-qualified installation technician. If you have not received hands-on training from a Cross-Link Composites LLC Instructor (or a pre-qualified trainer certified by Cross-Link Composites, LLC.) you should bring this to the attention of your company's management.

1. Inspect the reusable mold (1 & 2) ensuring that the flange gaskets (2) and mounting bolts & nuts (3) are in place. Coat all the inside metal surfaces with aerosol release agent. Install the fill neck, air vent, pressure gauge and foam gaskets. Set the prepared mold aside until needed.

### To Install Neck

- a) Place the hose clamp (6) over the small end of the neck.
- b) Push the small end of the neck (15) over the metal spout on the mold.
- c) Make sure that the hose clamp is below the weld stops on the spout.
- d) Tighten the hose clamp with a screwdriver (or a special hose clamp driver) being very careful not to allow the screwdriver to slip and puncture the neck.

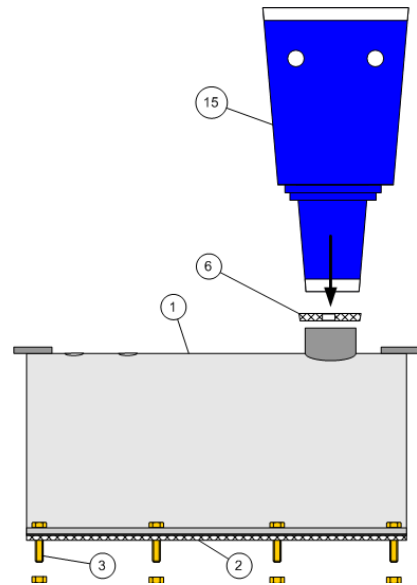

### To Install Gauge

- a) Remove nut and plastic washer from gauge stem. Leave foam washer in place.
- b) Push stem up through hole in metal mold.
- c) Refit plastic washer.
- d) Screw nut down hand tight.
- e) Snug up nut with 1-1/8" wrench held close to the wrench head.
- f) **CAUTION** — do not over-tighten. The stem flange may break off.
- g) Drop pinch clamp down stem.
- h) Grip vent stem with pinch clamp pincers with a piece of foam between the jaws so they do not slip.
- i) Put a drop of the supplied super glue (cyanoacrylate) on the gauge threads.
- j) Screw the gauge into the stem as far as it will go.
- k) Slide the pinch clamp up over the gauge threads and tighten the clamp with the pincers.

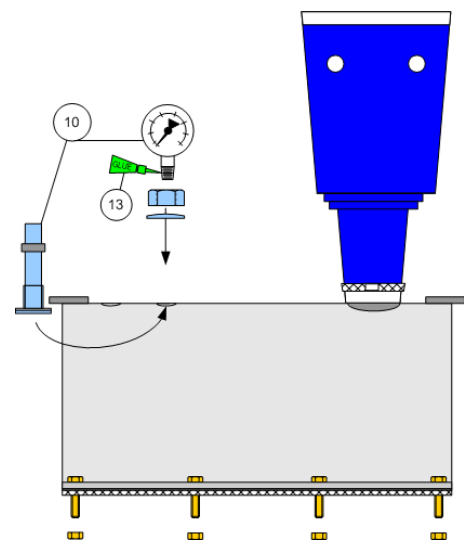

## Carbon-Ply Composite Repair System (CRS)

### To Install Vent

- a) Remove nut and plastic washer from vent stem. Leave foam washer in place.
- b) Push stem up through hole in metal mold.
- c) Refit plastic washer.
- d) Screw nut down hand tight.
- e) Snug up nut with a 1-1/8" wrench held close to the wrench head.
- f) **CAUTION** — do not over-tighten. The stem flange may break off.
- g) Push the ball valve vent onto the stem (9).
- h) Lightly tap with hammer until the vent barb is at least 1/2" down the stem.
- i) Push the clear plastic tube (8) onto the vent and over the barb.

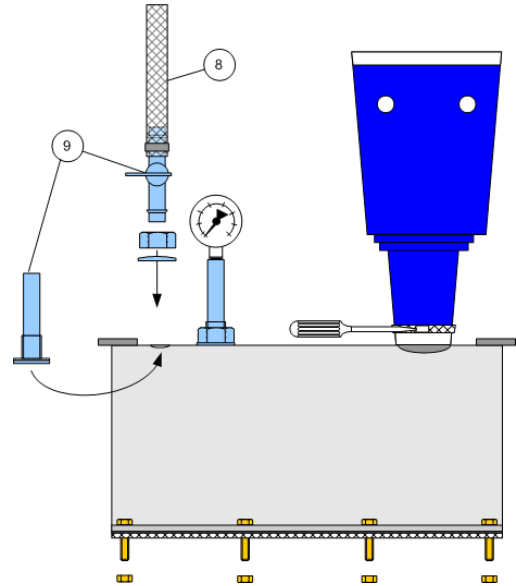

2. Spray the inside of the mold and both end seal gaskets with the Release Agent provided. This will make removal of these components after the repair much easier.
3. Inspect the pipe surface area to be repaired, ensure that the surface is clean and dry and is prepared to SSPC-SP3, SA-3 or NACE-3 finish. Check the defect area and ensure that all burrs, sharp corners and other stress-concentrating anomalies have been removed.
4. Mix the DFRE (22) according to the instruction on the container and apply it to the damaged area. Ensure that the applied DFRE is void free, contoured and even with the pipe surface.

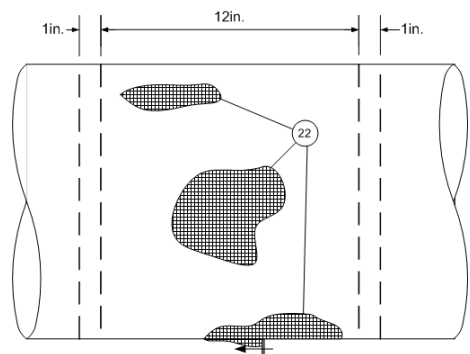

5. Wrap the appropriate sized fabric template around the pipe, centered over the defect, and secure it in place with tape. Mark the pipe circumferentially around both edges of the template with a permanent marker, such as a Sharpie pen. If you use soapstone or grease stick make sure that you Do Not write on the area to be coated as these products will prevent proper adhesion of resin to the pipe.
6. Also mark the pipe at a point 1" beyond the edge of the template on each side. These marks are the mold edge locator reference marks.
7. Remove the template and store for next time.
8. Mix the primer (23) according to the instructions on the can and carefully prime the area between the circumferential marks using the roller tray and nap roller (21). Work the primer into the surface. When finished this area must be completely covered with an even coating 2-3 mils thick.
9. While the primer is still wet, wrap the carbon fabric (24) on the primed area. Feed the carbon fiber from the top of the roller so that its natural curl (from being wound on the roller)

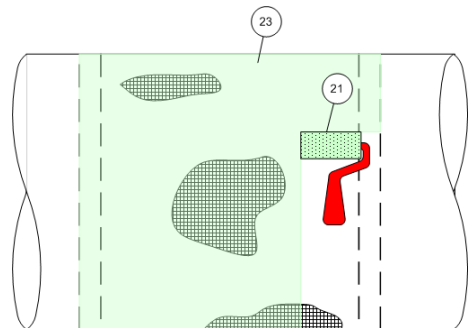

## Carbon-Ply Composite Repair System (CRS)

follows the curvature of the pipe. Wrap the carbon fiber hand-tight, tensioned and stacked evenly. Apply a little primer to the fabric under the last two inches of the wrap to hold it in place and press on it with the primer roller.

10. Install the re-usable containment system. Verify application of the release agent to the inside surfaces and also spray on the outside. Place the top half (1) (centered) over the primed area using the reference marks ensuring that the fill spout and gauge are at top dead center. With the lengthwise gaskets and bolts in place, raise the bottom half (4) to interface with the top half. Tighten the diagonal corner flange bolts first to hold the mold in place. Now tighten the rest of the bolts.
11. Find the circular End Seals(5) and remove the two 7/16" nuts and gasket cover plate, remove the gasket from the two studs and wrap the end seals around the pipe replace the gasket and cover plate. Spray the end seals inner edge with release agent. Slide the end seals into the mold and match the reference marks. Tighten the 7/16" seal rubber compression nuts moving around the seal ring in approximately 90 deg steps until all nuts are tightened evenly and the seal is effective. Lightly spray the outer edge of the seal with release agent. If you spill resin in this area it can now be easily removed.
12. Open vent and direct its tube into an empty can.
13. To Pre-Mix Resin - Install the Jiffy mixer in the chuck of a 500 to 600 rpm, 1/2" air or electric drill. Place Part A can between your feet and hold tight to prevent the can spinning. Hold the drill firmly and submerge the mixer in the Part A (25) midway down. Turn drill on and move mixer up and down and around in the material. After a few seconds move the mixer to the bottom of the can and incorporate the thicker material at the bottom until it is all the same consistency. This may take up to a minute.

14. Now add Part B (25) by pouring it into the vortex caused by the mixing head and continue mixing until the two components are thoroughly mixed together. This will take from one to two minutes depending on temperature.

15. Stop the Jiffy mixer before removing it from the can. Place the head in a used carton or can and spin the head briefly to remove the bulk of the resin.
16. As each kit is mixed a second person should pour it into the mold. All material should be in the mold within 10 minutes.

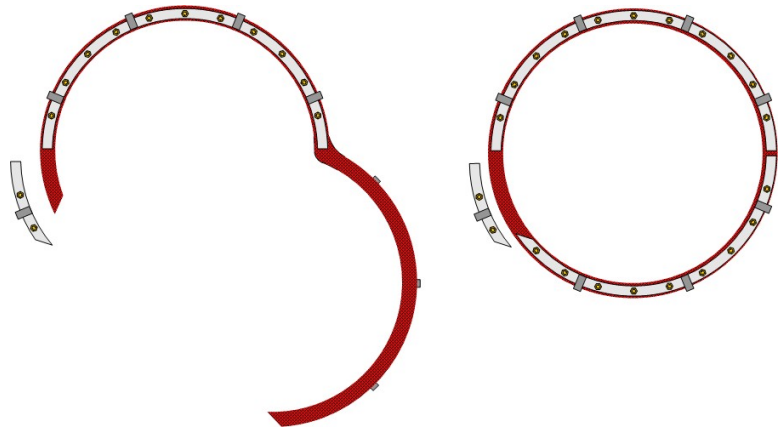
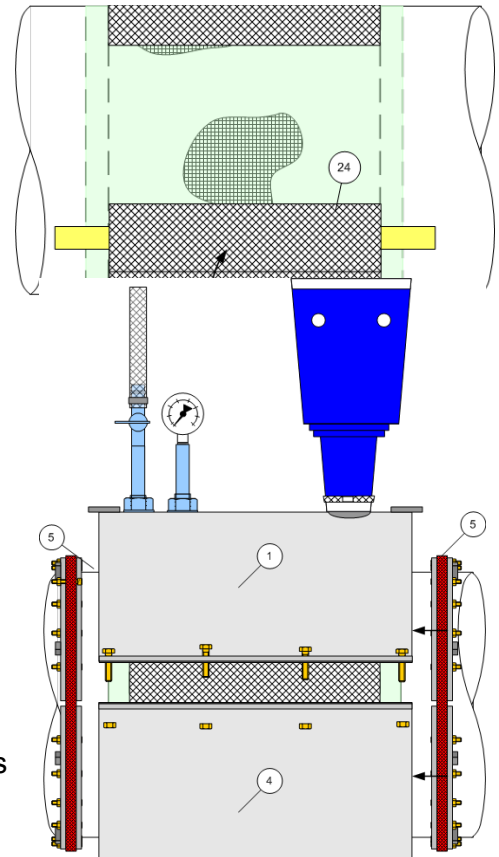

## Carbon-Ply Composite Repair System (CRS)

17. Roll over the top of the neck to just below the holes and hold the neck up high and tight with the top open.
18. The second person should hold the can 10" or more above the neck and pour the resin into the neck without spilling it on the neck. Repeat with rest of the mixed resin cans but do not fill neck more than 4" from holes.
19. Roll the neck top back and thread the fiberglass rod (16) through the holes so that 2/3 is sticking out from one side. Hold the neck closed just below the rod and grab the long end of the rod with the other hand.
20. While holding the neck up with one hand twist the rod, gathering the neck around it above your hand. Continue twisting the rod making sure the bottom of the neck does not twist. As soon as all of the air has escaped through the vent and resin flows freely shut off the vent valve and continue twisting the neck. Watch the gauge and stop twisting at around 12 psi.
21. Wrap the wire (7) around the long end of the rod and move the rod to a vertical position near an end seal bolt. Wrap the wire around the bolt to hold it in place.
22. **IMPORTANT** — install a cable tie (17) around the neck just above the steel spout and tighten with the tie tool. This is to reduce the diameter of the neck at this point so that the mold can be removed easier. Watch the gauge at this point and do not over tighten.
23. Look for leaks, and tighten any nuts or bolts at the leak point.
24. Caution: The resin will get very hot shortly (up to 350°F). Once it cools to 130°F the repair is done and the mold can be removed.
25. Remove the vent and gauge nuts and washers and cut off the stems as close to the mold as possible with a hacksaw.
26. Cut the neck off level with the top of the mold spout and remove any resin that extends beyond the diameter of the steel spout so the mold top can be easily removed.
27. Remove the horizontal flange bolts.
28. Remove both halves of the mold.

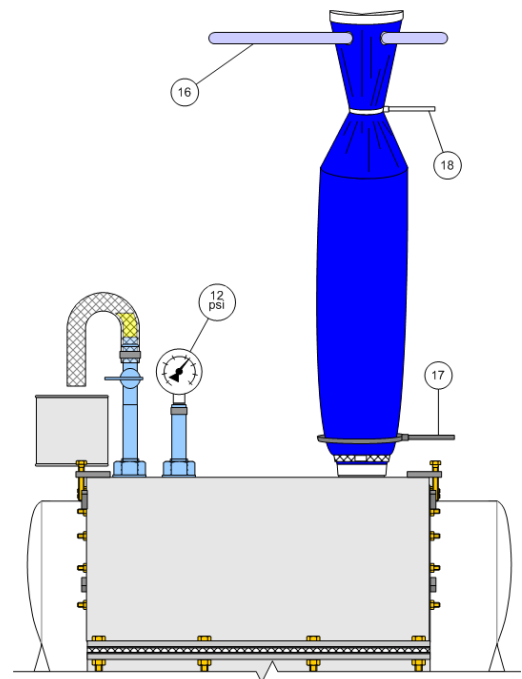
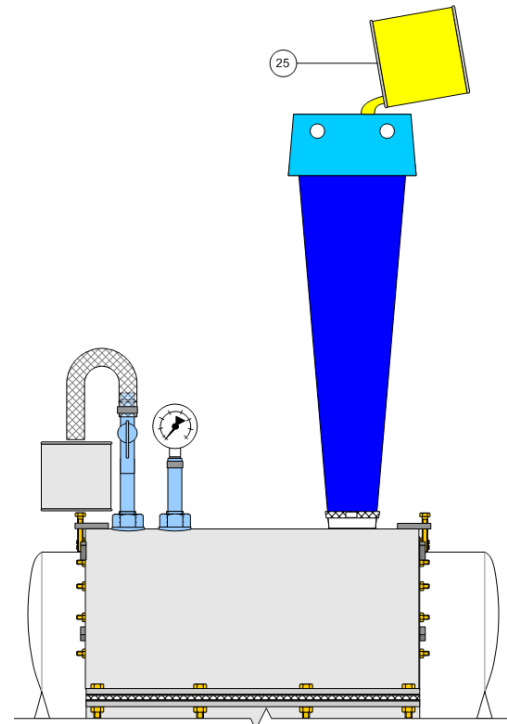

**You may now return the pipe to full service and backfill.**

## Carbon-Ply Composite Repair System (CRS)

### Properties Carbon-Ply Composite Repair System (CRS)

COMPRESSIVE STRENGTH:	12,345 psi (85.12 MPa)	ASTM D-695
COMPRESSIVE MODULUS OF ELASTICITY:	3.61 x 10 <sup>5</sup> psi (2489 MPa)	ASTM D-695
POISSONS RATIO:	Axial – 0.035 Hoop - 0.32	ASTM D-3039
YOUNGS MODULUS:	Axial – 752,746 psi (5.19 GPa) Hoop – 9,616,002 psi (66.3 GPa)	ASTM D-3039
COEFFICIENT OF LINEAR THERMAL EXPANSION (50 °F to 170 °F):	0.16 x 10 <sup>-6</sup> in./in./°F	ASTM D-696
FLEXURAL STRENGTH:	89,775 psi (619 MPa)	ASTM D-790
FLEXURAL MODULUS OF ELASTICITY:	7.84 x 10 <sup>6</sup> psi (54.1 GPa)	ASTM D-790
TENSILE ELONGATION AT BREAK:	0.618%	ASTM D-638
TENSILE STRENGTH:	Axial – 4,178 psi (28.8 MPa) Hoop – 109,996 psi (758.4 MPa)	ASTM D-638
TENSILE MODULUS OF ELASTICITY:	Axial – 0.9009 x 10 <sup>6</sup> psi (6.2 GPa) Hoop: 8.612 x 10 <sup>6</sup> psi (59.4 GPa)	ASTM D-638
COMPOSITE LAP SHEAR STRENGTH:	>2,339 psi with Primer (16.1MPa)	ASTM D-1002
SHEAR STRENGTH:	8,233 psi (56.8 Mpa)	ASTM D-5379
SHEAR MODULUS:	6.17 x 10 <sup>5</sup> psi (4.25 GPa)	ASTM D-5379
HEAT DISTORTION TEMP. OF COMPOSITE:	>400 °F (204.4 °C)	ASTM D-6604
CATHODIC DISBONDMENT @ 75 °F & 120 °F:	No visual undercutting or corrosion blistering was observed	ASTM G 8-96
IMPACT TEST – MODIFIED GARDNER:	140 inch-lbs (15.8 N.m) using 4 lb weight with 5/8" Tup	ASTM G-14
SHORE D HARDNESS:	85	ASTM D-2583

### Product Information – Carbon-Ply CRS Primer

ADHESIVE LAPSHEAR:	2,559 psi (17.6 MPa) over a 2-3 mil surface profile	ASTM D-1002
HARDNESS:	70 – 80 Shore D	ASTM D-2583
VOC:	0.16 lbs/gallon (20 g/L)	
SOLIDS:	98.2%	
FLASH POINT:	> 100°F (37.8 °C)	
COLOR:	Resin – Green Hardener – Amber Mix – Green	
SPECIFIC GRAVITY:	Part A – 1.24, Part B – 0.98	
MIXED VISCOSITY:	800 cps to 1200 cps	
UNIT COVERAGE:	20 ft <sup>2</sup> @ 4 mils	
APPLICATION TEMPERATURE:	13 °C (55 °F) to 37 °C (100 °F)	
MIX RATIO:	2.5 Part A to 1 Part B by weight	
PACKAGING per Unit:	Resin – NH 0.44 lbs., 8.3 fl oz in a 1 pint can, Hardener – H 0.15 lbs., 2.4 fl oz in a half pint can	
POT LIFE:	300 min. @ 21°C (70°F)	
SHELF LIFE:	18 months stored unopened in a temperature controlled environment	
CLEAN UP:	IMPAX IXT-59 or similar epoxy solvent	

Crosslink Composites, LLC. [www.clcomposites.com](http://www.clcomposites.com)  
Assembled under license by PLCS Inc., 102 Gaither Drive, Unit 1, Mt. Laurel, NJ 08054

## Carbon-Ply Composite Repair System (CRS)

### Product Information – Carbon-Ply DFRE Putty

COMPRESSIVE STRENGTH:	10,947 psi (75.5 MPa)	ASTM D-695
COMPRESSIVE MODULUS OF ELASTICITY:	4.44 x 10 <sup>5</sup> psi (3061 MPa)	ASTM D-695
COEFFICIENT OF LINEAR THERMAL EXPANSION (50°F to 170°F):	15.8 x 10 <sup>-6</sup> in./in./°F	ASTM D-696
ELONGATION:	0.55%	ASTM D-638
ADHESIVE LAPSHEAR STRENGTH:	2,000 psi (13.8 MPa)	ASTM D-1002
TENSILE STRENGTH:	3,862 psi (391.3 MPa)	ASTM D-638
TENSILE MODULUS:	8.54 x 10 <sup>5</sup> psi (5888 MPa)	ASTM D-638
FLEXURAL STRENGTH:	7,222 psi (49.8 MPa)	ASTM D-790
FLEXURAL MODULUS:	2.9 x 10 <sup>5</sup> psi (1724 MPa)	ASTM D-790
GLASS TRANSITION TEMPERATURE (T <sub>g</sub> ):	194 °F (90 °C)	ASTM D-1340
HEAT DISTORTION TEMPERATURE:	187 °F (86 °C)	ASTM D-648
HARDNESS:	85 Shore D	
COLOR:	Resin – Yellow Hardener – White Mix – Yellow	
SPECIFIC GRAVITY:	Part A – 1.4. Part B – 1.63	
MIXED VISCOSITY:	Thixotropic Paste	
APPLICATION TEMPERATURE:	7 °C (45 °F) to 35 °C (95 °F)	
MIX RATIO:	2 Part A to 1 Part B by Volume	
PACKAGING per Unit:	Resin – NH 0.47 lbs., 5 fl oz in a pint can, Hardener – H 0.21 lbs 2.3 fl oz in an half pint can	
CURE TIME (approximate):	30 minutes with repair exotherm	
POT LIFE:	15 min. @ 21 °C (70 °F)	
SHELF LIFE:	18 months stored unopened in a temperature controlled environment	
CLEAN UP:	IMPAX IXT-59 or similar epoxy solvent	

### Product Information – Carbon-Ply CRS Resin & Hardener

GLASS TRANSITION TEMPERATURE:	201.6 °F (94.2 °C)
HARDNESS:	82 – 88 Shore D
COLOR:	Resin – Yellow Hardener – Reddish Mix – Yellow
SPECIFIC GRAVITY:	Part A – 1.21, Part B 1.0
MIXED VISCOSITY:	1,000 cps to 2,000 cps (2 pascal seconds)
APPLICATION TEMPERATURE:	13 °C (55 °F) to 35 °C (95 °F)
MIX RATIO:	6.55 parts resin : 1 part hardener by weight
PACKAGING per Unit:	Resin – NH 7.91 lbs., 0.78 gal in a 1 gal can, Hardener – H 1.24 lbs., 0.15 gal in a quart can
CURE TIME (approximate):	30 minutes to exotherm @ 21 °C (70 °F) Achieves full cure after exotherm cools to 130 °F (54.4 °C)
GEL TIME:	20 to 24 min. @ 21 °C (70 °F)
SHELF LIFE:	18 months stored unopened in a temperature controlled environment
CLEAN UP:	IMPAX IXT-59 or similar epoxy solvent

Crosslink Composites, LLC. [www.clcomposites.com](http://www.clcomposites.com)  
Assembled under license by PLCS Inc., 102 Gaither Drive, Unit 1, Mt. Laurel, NJ 08054

## **Carbon-Ply Composite Repair System (CRS)**